

Use of Virtools for cockpit design, testing of force feedback device and teaching

Joonas Laitinen, researcher,
Tampere university of technology

Purposes of use in Laboratory of virtual technology

- Cockpit design
 - Project: Kovite
- Device prototyping platform
 - Project: HandsOn
- Illustration and teaching tool
 - Several small projects of different courses
 - Project:Husko

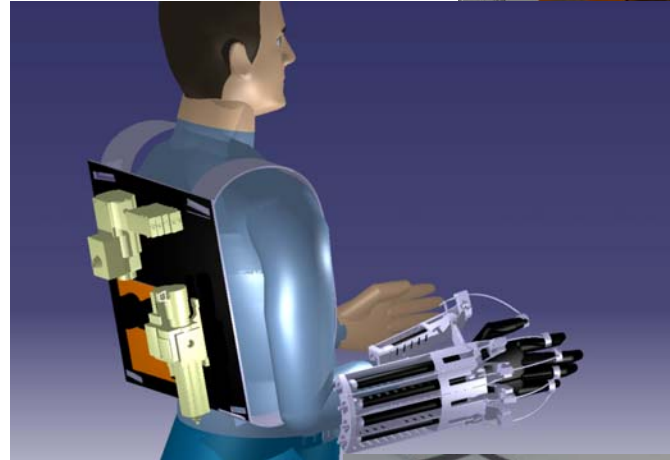

Background

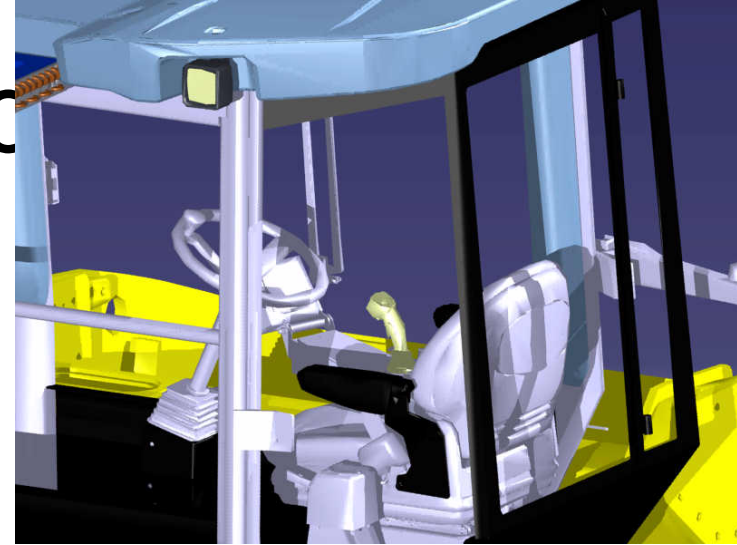

- Problems with visualizing Catia models
 - Cave was not supported
 - Fob with ERC not supported
 - Need for buying ultra expensive Conduit by Fakespace
- Tests with Catia V5 both in PC and Onyx4 environments
- Alternatively tested other programs with Onyx4 like: WalkInSide, Saranav, DivisionMockUp etc.

Virtools in cockpit design

- Visualized models of
 - Catia & Solidworks
 - Unigraph(stp)
 - I-deas(stp)
 - Aveva(stp)
- Virtools has been found useful when modeling by Catia
- 3dxml makes it possible to transfer and visualize quite big cad-designs without noticeable reduction of visual quality
- Automatic 3dxml loader accelerates the cycles, when virtual testing will be performed during designing

Design goals

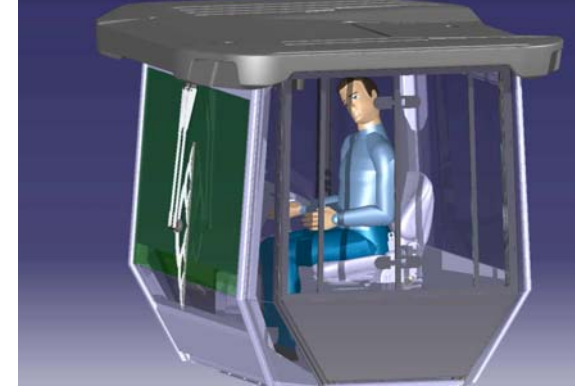

- Visibility
 - Refers out of the cockpit as well as visibility of the controls inside
 - Scaling the controls inside seems the most challenging task while working with VR
- Functionality
 - Extra work required if functionalities programmed
 - Moving boom, adjustable chair and controls etc.
- Ergonomics
 - Need of feedback generated by device or some passive way like transparent panel
 - Studies can be performed also by recording motion of driver by trackers
- Safety
 - Computational results can be clarified
- Industrial design
 - Visual enjoyability
 - Need of careful modeling, texturing and lightning

Web player and marketing

- Cave-models can be adapted to use with web player
- Innovations can be approved by clientele by means of web models(maybe)
- Advertisement purposes

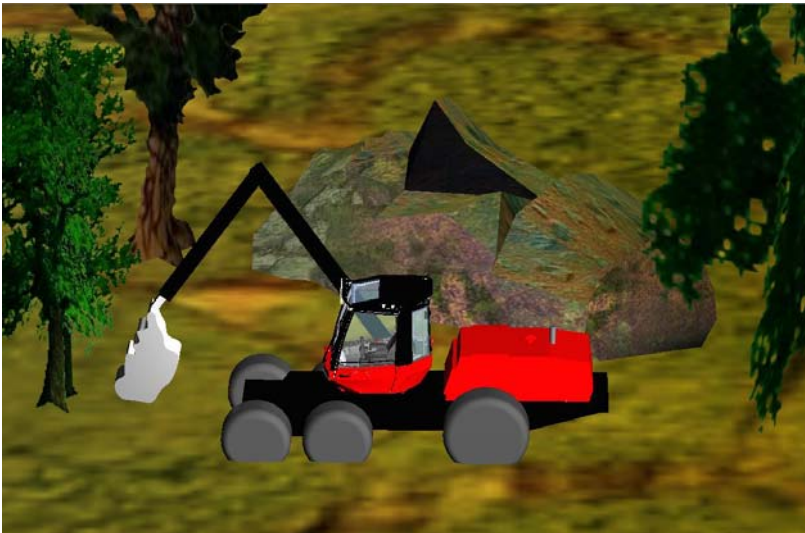

Force feedback device

- Test applications: cad-related design and manufacturing processes, simulation and product planning tasks(cabins)
- Benefits come out when modifications are made rapidly
- Can be used with passive feedback when its need for set limits of moving

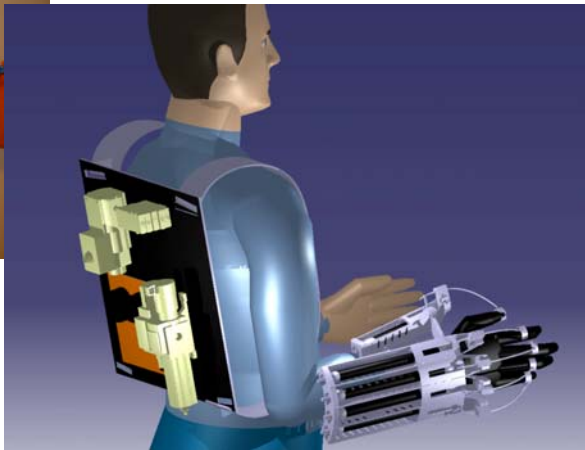
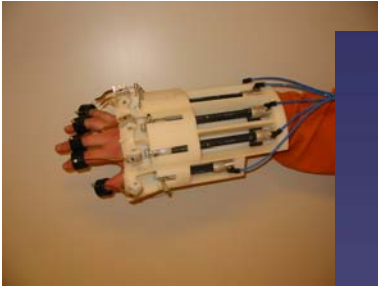

Structure

- plastic body molded on the back of the user's hand
 - Made by rapid-prototyping machine
- muscle actuators are attached to the exoskeleton with adjustable aluminum plate
 - Exhibits many of the properties found in real muscle
 - Spring-like characteristic
 - Physical flexibility
 - Light weight
- One key feature of the glove design is light weight
- The muscles controlling the motion of the four fingers are joined to a thimbles

Software and devices

- Head tracking and tracking of fingertips by Ascension Flock of Bird
 - We have abandoned using 5dt glove, because of its low accuracy and uncertainty
- VRPN interface to connect feedback device and PC with Virtools
 - Glove control PC is controlling solenoid valves and acts vrpn server
- Virtool's own collision detection algorithm in use
 - Effective
 - Makes the work easier

PC-cluster

Glove control PC

Ethernet

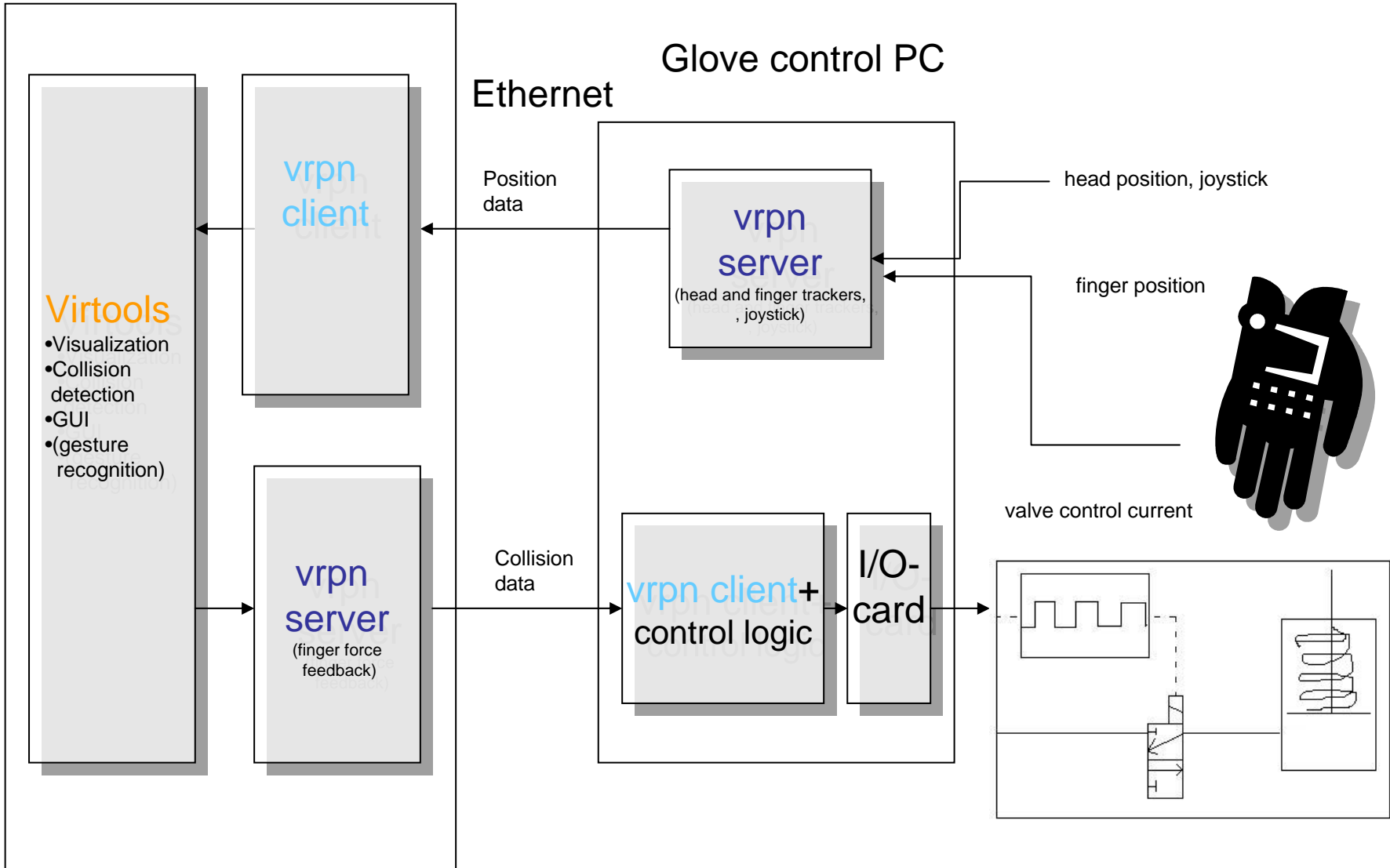

Future work

- We try to make possible for the end-user to participate design process at conceptual design phase
- Need more user tests to acquire information on its additional value on evaluation of designs
- Different kind of valves and combinations of valves have to be tested to find most workable steering system
- Alternative tracking systems have to be tested to find the most suitable solution
 - Need for optical tracking

Virtools in education

- Students have studied the program on course "VR design methods"
 - Different kind of 3D-models, like motor's functions, architectural designs, and advertisement models converted to Virtools during lessons
- UI has been found challenging to learn
 - Lots of "hidden functions" (attributes)
 - Different from any other CAD and VR software
 - Fuzzy menus
- However, studying is rewarding
 - Easy to make some functionalities by means of Minisite tips
 - Virtools is good tool when there is need for teaching basics of VR
 - Referential "sprites" and steering of devices are modeled illustrative



Activities going on

- Some guys are doing CAE groupwork on topic "Virtools 3dxml loader and different assemblies in Catia"
 - Main purpose is to collect experiences how to use loader
- Tests with different cad-formats are going on
 - At the same time some models will be textured and some functions may be scripted
- Tests and configuration with new PC and two active stereo projectors
 - Need for develop the resolution of our low-cost IPT system